



MODEL 509

**TWO-PIECE CLOSED COUPLE, ROUND BOWL,
12" ROUGH IN, GRAVITY FEED
ROUND TOILET WITH SECONDARY DRAIN SYSTEM
VITREOUS CHINA**

FEATURES:

- Exclusive Penguin Protection: secondary drain system that helps protect against toilet overflows
- Specially designed or adapted for the use or benefit of the blind or other physically or mentally handicapped persons
- HET 1.28gal/ 4.8Liter per flush **WATERSENSE LISTED**
- 1000g MaP score
- New taller round bowl design that meet ADA with approved seat
- Fluidmaster 3" flushing system
- Fluidmaster fill valve
- Fully glazed trapway with Sani-Glaze
- 5 Year limited warranty
- Minimum operating pressure of 15 PSI



APPLICABLE CODES & STANDARDS:

- ASME A112.19.2
- IGC 252-07
- CSA B45-02 (Supplement No. 1-2004)
- IAPMO/ UPC
- ADA Compliant

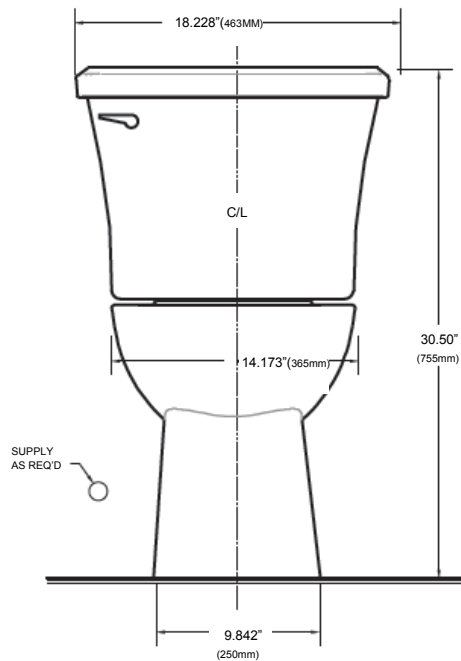
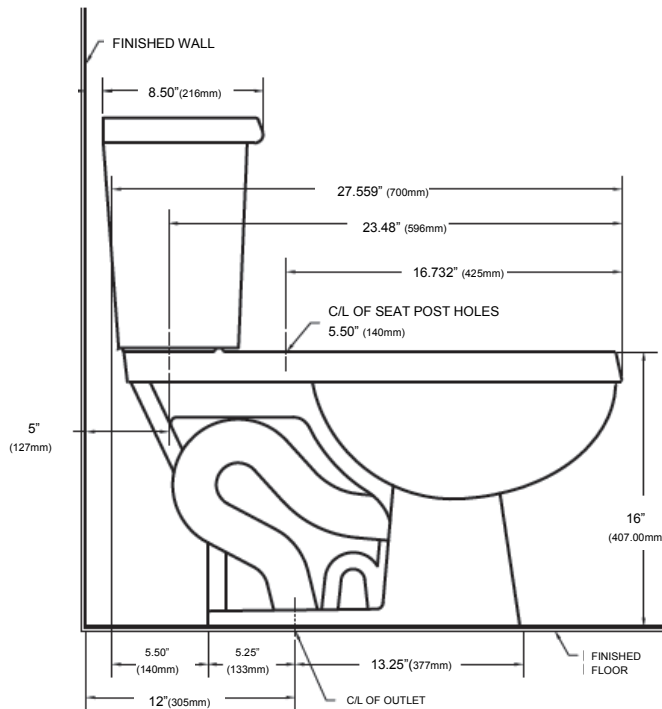

NOTES:

THIS TOILET IS DESIGNED TO ROUGH-IN AT MINIMUM DIMENSIONS OF 12" (305mm) FROM FINISHED WALL TO C/L OF OUTLET. SUPPLY NOT INCLUDED WITH FIXTURE AND MUST BE ORDERED SEPARATELY.

*DIMENSION SHOWN FOR LOCATION OF SUPPLY IS SUGGESTED. FOR ADDITIONAL INFORMATION REFER TO INSTALLATION INSTRUCTIONS SUPPLIED.

www.penguintoilets.com

